

**audio research**  
HIGH DEFINITION®

3900 ANNAPOLIS LANE NORTH / PLYMOUTH, MINNESOTA 55447-5447 / PHONE: 763-577-9700 FAX 763-577 0323

CLASSIC 60  
STEREO POWER AMPLIFIER  
OWNER'S MANUAL

1-1-89

## TABLE OF CONTENTS

| <u>SECTION</u>                | <u>PAGE</u> |
|-------------------------------|-------------|
| PREFACE                       | 1           |
| INTRODUCTION                  | 1           |
| CONSTRUCTION AND TESTING      | 2           |
| PACKAGING                     | 2           |
| UNPACKING                     | 2           |
| ACCESSORIES                   | 2           |
| WARNINGS                      | 3           |
| PREPARATION FOR USE           | 3-4         |
| FRONT PANEL CONTROLS          | 4           |
| USE OF CONTROLS               | 4           |
| INSTALLATION                  | 4           |
| CONNECTIONS INSTRUCTIONS      | 5-6         |
| OPERATING PROCEDURE           | 6           |
| ADJUSTMENT PROCEDURE          | 7-8         |
| SERVO BALANCE CALIBRATION     | 8           |
| SERVICING                     | 8-9         |
| CLEANING                      | 9           |
| WARRANTY TERMS AND CONDITIONS | 10-11       |
| WARRANTY OUTSIDE THE USA      | 11          |
| SPECIFICATIONS                | 12          |
| ADDENDUM: SCHEMATIC           |             |

## PREFACE

Please take time to carefully read and understand the following instructions before you install or attempt to operate your CLASSIC 60 hybrid stereo power amplifier. Familiarizing yourself with pertinent facts about your amplifier and its correct operating procedures will help assure you of maximum musical satisfaction and reliable operation. The effort you invest now will be well rewarded as time goes by.

## INTRODUCTION

The CLASSIC 60 stereo power amplifier offers natural musicality, dynamics and reliability unmatched by any other amplifier in its price range. It represents the very latest, most sophisticated design effort by Audio Research engineers to produce an amplifier capable of driving a wide range of contemporary loudspeaker designs with control and musical grace, in a physical package that is pragmatically sized and user-friendly.

The CLASSIC 60 is rated to provide 60 watts of output power into 4, 8 and 16 ohm loads. And, like its less powerful predecessor (the CLASSIC 30), the CLASSIC 60 features a triode-configured output stage while retaining the partial cathode coupling that all Audio Research vacuum tube and hybrid amplifiers employ. Triode operation, in conjunction with partial cathode coupling, results in significant sonic improvement over conventional tube output circuits, yielding richer and more lifelike musical performance -- with a sense of power and control that belies its 60 watt rating.

In addition, triode operation offers more reliable operation during the life of the output tubes. Because the screen (accelerating) grids are connected to the plates (anodes), the normal stress of conventional pentode operation is not present. Longer tube life as well as less "catastrophic" tube failure can be expected as additional bonuses to the improved performance. Service life of internal components (including tubes) is further enhanced by quiet, efficient fan cooling.

Like other more recent amplifier designs from Audio Research, the CLASSIC 60 stereo power amplifier is a hybrid, using precision semiconductors in the input stage along with two 6FQ7 driver tubes in each channel (thereby reducing the threat of damage in the event of a tube "arc," without the need for costly protection circuitry).

The CLASSIC 60 is also constructed to the same rigorous standards as other more costly Audio Research equipment. Close inspection reveals the same heavy-duty, precision printed wiring boards, audiophile-grade capacitors and costly point-to-point litzwire. In addition, the CLASSIC 60 incorporates a novel new circuit which readjusts the tube bias regulator automatically for power line voltage changes. You don't have to be concerned about whether the bias is set correctly for your line voltage. It is, automatically! And, a sophisticated servo circuit continuously monitors and maintains DC balance in each pair of output tubes in each channel. The result is an amplifier that maintains its stunning powers of resolution without tweaking or tinkering. (When the output tubes need replacing, a single bias adjustment is all that's required to restore original performance.)

The CLASSIC 60 is an excellent match for high-resolution loudspeakers of moderate size and power demands. It has more than enough output to reach lifelike sound pressure levels in even large real-world listening rooms. Thanks to its incredible power of resolution, the CLASSIC 60 yields more information, as well as a more satisfying musical experience, at lower levels than more conventional amplifiers are capable of.

## CONSTRUCTION AND TESTING

Like every Audio Research product, your CLASSIC 60 power amplifier has been designed and carefully handcrafted in the U.S.A., using precision mechanical parts, electronic components and assembly procedures similar to those used in the manufacture of military electronics, aircraft electronics and scientific instruments. To assure performance standards, each CLASSIC 60 is visually inspected at several assembly points, test run, electronically tested and sonically evaluated prior to shipment.

This time-consuming "perfectionist" approach to the design and manufacture of audio equipment is intended to provide you with the best in musical satisfaction and lasting value.

## PACKAGING

Save all the packaging. Your Audio Research amplifier is a precision electronic instrument and should be properly cartoned any time shipment is made. Because of its weight, it is highly probable that the unit will be damaged during shipment if repackaged in cartoning other than that designed for the unit. It is also important, again because of the unit's weight, to pack each tube individually in its own carton.

You may not have occasion to return the unit to the factory for service, but if that should prove necessary, or other occasion to ship it occurs, the original packaging may save your investment from unnecessary damage, delay and expense.

REMEMBER: Remove all vacuum tubes from their sockets and package them in the individual cartons to avoid damage in shipment. Mark each tube with its "V" number so that proper relocation can occur at re-installation.

## UNPACKING

The CLASSIC 60 is packed within two cartons (inner and outer) which have polyfoam panels in between. Because of the weight of the unit and because it is a precision electronic instrument it is necessary to take reasonable care in its unpacking and preparation for use.

It is best to have a large, open work area with two people available to help. Set the carton upright in the center of the work area and with a knife or razor blade carefully slit the taped edges of the outer carton's top flaps. Fold the flaps to the sides and while holding the inner carton in place, roll the unit upside down. You can now lift the outer carton off and set it and the foam filler panels aside. Now slit the inner carton's bottom flaps taped edges. Again, fold the flaps over and while holding the unit in, roll it over as before. You can now lift the inner carton off to find your CLASSIC 60 sitting upright, undamaged and uncartoned. Carefully remove the plastic wrap. Now, while you remember how, reassemble the carton system for future use.

## ACCESSORIES

- 1 - Phillips screwdriver (for cover removal)
- 1 - Plastic screwdriver (for adjustments)

Spare Fuses:

- 2 - 1/4 Amp AGC 250V normal-blow with 100V, 120V and 220/240V units
- 2 - 6 1/4 Amp MDX 125V slo-blow with 120V units
- 2 - 7 Amp MDS 125V slo-blow with 100V units
- 2 - 3 Amp MDZ 250V slo-blow with 220/240V units

## WARNINGS

1. To prevent fire or shock hazard, do not expose your CLASSIC 60 to rain or moisture.
2. This unit contains voltages which can cause serious injury or death. Do not operate with covers removed. Refer servicing to your authorized Audio Research dealer or other qualified personnel.
3. The 16-gauge, 3-conductor power cord on your CLASSIC 60 is equipped with a standard three-prong grounding plug. If used normally, it will provide a safe earth ground connection of the chassis. Refer to the Section on AC Power Connections for detailed information.
4. For continued protection against fire hazard, replace fuses only with the same type and rating of fuses as specified at individual fuse holders.

## IMPORTANT NOTE REGARDING FAN OPERATION

Your CLASSIC 60 amplifier has two small cooling fans mounted to the inside rear of the top cover. These fans must be connected to an internal power socket after the tubes have been installed, but before the amplifier is connected to an external AC power line. Once you have installed the vacuum tubes according to the instructions in this Manual, set the top cover in position on the amplifier. Lifting the back side of the cover, reach underneath, grasp the fan power plug hanging from the underside of the cover and plug into the power socket located just behind the main power supply capacitors on the circuit board. BE SURE THE AMPLIFIER IS NOT CONNECTED TO EXTERNAL AC POWER WHEN YOU CONNECT FANS TO INTERNAL POWER SOURCE. Once fans have been plugged into the internal socket, reposition top cover and secure with retaining screws.

## PREPARATION FOR USE

Your CLASSIC 60 amplifier is shipped with all of the vacuum tubes removed, packaged and wrapped so that they will not be broken or internally damaged in shipment. It is necessary to install these before using your amplifier.

Your CLASSIC 60 utilizes a total of twelve (12) vacuum tubes. Eight (8) are type 6550 power output tubes (four per channel). Four (4) are type 6FQ7 "driver" tubes (two per channel).

These tubes are packaged separately in individual cartons located under the protective cage. It is important to carefully install these vacuum tubes in their proper locations, observing the "V" markings on each tube and their corresponding sockets. Proceed as follows:

- A. Using the Phillips screwdriver provided, remove the top cage, momentarily setting it and the screws aside.
- B. Remove the 12 tubes individually from their cartons and insert them in their proper sockets.
- C. Reposition the protective cage and connect fans to internal socket. Secure cage with screws.
- D. Save the Phillips screwdriver and the vacuum tube cartons for possible future use. Storing these items within the CLASSIC 60 packaging carton is a good way to assure finding them again.

Note: Contact enhancers -- such as the commercial preparation "Tweek" -- are not recommended for use on vacuum tube contact pins. With continual exposure to heat and air, these substances can form gummy, dust-collecting residues which actually reduce contact and degrade sonic performance. Proper external use of these preparations -- on interconnect plugs, speaker connections, etc., -- is subject to the discretion of the owner.

### FRONT PANEL CONTROLS

The front panel has:

- |                 |  |
|-----------------|--|
| 1 Switch        | 1 - Power Line On-Off                              |
| 2 Fuse Holders: | 1 - Power Line<br>1 - High Voltage                 |
| 2 Indicators:   | 1 - Power "ON" (Green)<br>1 - High Voltage (Green) |

### USE OF CONTROLS

POWER-ON SWITCH: Initiates/terminates AC line power to the amplifier. Function indicated by green LED at right of toggle switch.

Note: Audio Research does not recommend leaving your CLASSIC 60 "on" 24 hours a day as is the custom of some audiophiles to achieve maximum sonic performance on demand. While this is often recommended for solid-state equipment, Audio Research does not recommend this procedure for vacuum tube power amplifiers. (2,000 hours of tube life will pass by in 84 days!)

### INSTALLATION

Two internal cooling fans located at the rear of your CLASSIC 60 help preserve component and tube life and also allow installation within a ventilated cabinet. However, the following guidelines should be observed in order to maximize the performance and service life of your amplifier.

To insure normal component life and safe operation this unit must be operated only in a horizontal (upright) position. Adequate air flow and proper cooling thereby can occur only if there is no restriction below, behind and above the unit.

The five (5) special non-marring elastomer feet provide adequate spacing only from a smooth, hard surface. Never operate the unit while it is sitting on a surface such as a rug or carpet.

If the unit is to be operated in an enclosure such as an equipment rack, make certain that adequate air flow above and below the unit is provided. The "ambient" operating temperature should never exceed 120°F or 49°C. Audio Research Corporation Rack Mount Ventilators (RMV-3) must be used above and below each unit. Improper installation will cause premature tube failure and will affect your warranty, as well as the service life of the unit.

It is normal for a vacuum tube power amplifier to run quite "warm," and if used for prolonged periods, "hot" to the touch. All components within are, however, operated at safe, conservative levels and will not be improperly affected thereby, providing the requirements outlined above are adhered to.

## CONNECTION INSTRUCTIONS

The rear panel has:

- Input Connections (Right and Left channels)
- Output Barrier Terminal Blocks (Right and Left channels)
- Power Line Cord

**IMPORTANT:** Use the best available speaker wires and interconnects. Audio Research cannot emphasize this enough. As better components and systems are developed, it becomes increasingly important to avoid the limitations of inferior system interconnections. For best results we recommend Audio Research LITZLINK® interconnects and LITZLINE® speaker cables.

Audio Research uses circuitry called "partial cathode coupling" in all of its vacuum tube and hybrid power amplifier designs. This requires the 4 ohm taps of the CLASSIC 60's outputs to be grounded (internally). This is of no consequence when using most loudspeakers. Simply connect the "negative" speaker lead to "0" and the "positive" speaker lead to 4, 8 or 16 ohms, as required.

Some loudspeakers, however, including the Polk SDAs, Infinity RS-1 Series, and possibly some electrostatic designs have "common ground" systems, either by hookup between the speakers or in a special crossover device. Most headphone adaptor boxes also have a common ground. In these instances it is important to connect the "negative" speaker leads (or headphone common leads) to the "4" ohm taps rather than the "0" ohm taps to avoid shorting the amplifier or causing monaural performance to occur. Use either "0" ohms or "16" ohms for the "positive" speaker leads. (The "0" ohm tap will provide an inverted signal. Contact your authorized Audio Research dealer or Audio Research Customer Service Department for help with these special cases.)

It is important sonically that your entire system be connected so that the audio signal arriving at the speakers has correct, or "absolute" polarity (i.e., non-inverted). Connect the black or "-" speaker terminal to the wire that connects to the "0" terminal on the CLASSIC 60. Connect the red or "+" speaker terminal to the wire that connects to the "4," "8" or "16" terminal on the CLASSIC 60. Use the best available speaker cables and tighten the screw terminals securely with a large screwdriver to ensure best sonic results.

**MATCHING.** It is important to use as close as possible an impedance match between the amplifier and speaker for optimum transfer of power to the speaker with minimum distortion. In the case of speaker systems with significant variations in impedance throughout the frequency spectrum, such as most electrostatic types, determine the best impedance match empirically for best overall sonic results.

Connect the CLASSIC 60 input to the preamplifier or electronic crossover, using only the highest grade of audio interconnect cables. To avoid sonic degradation use the shortest practical length of cables.

**AC POWER CONNECTIONS.** It is essential that the CLASSIC 60 amplifier be connected to a wall AC power receptacle, or a similar heavy-duty source. It must not be connected to convenience receptacles on preamplifiers, etc., or the full sonic capabilities of both the CLASSIC 60 and the preamplifier may be compromised. Furthermore, the proper control of start-up and shut-down surges may not occur unless the power switch on the front of the CLASSIC 60 is actually used for on/off control of the amplifier. The AC power source for the CLASSIC 60 amplifier should be capable of supplying 15 amperes for 100 or 120 volt units, or 10 amperes for 220 or 240 volt units.

For the very best performance on domestic 100 or 120 volt circuits, the CLASSIC 60 should be connected to its own AC power circuit branch, protected by a 15 amp breaker. The preamplifier and other audio equipment should be connected to a different power circuit and breaker. If the power receptacle of the CLASSIC 60 is more than 25 feet from the building power entrance and breaker box, it would be preferable to use installed wiring capable of 30 amperes to minimize voltage drop, using a 15 amp breaker. Avoid the use of extension cords. If they must be used on a temporary basis, use 14-gauge or heavier cords.

The CLASSIC 60 utilizes a compatible grounding system that generally does not require a "ground lifter" adapter plug on the AC power cord to minimize hum. The power cord on your CLASSIC 60 has a standard three-prong grounding plug to provide maximum safety when it is connected to a ground wall receptacle. If there is any question regarding the safety of grounding procedures, be certain to seek competent help with the installation.

If electronic crossovers or other AC powered equipment is used with the CLASSIC 60, it may be necessary to use "ground lifter" adapters on the power plugs of that equipment to minimize system hum. Generally, the lowest hum is achieved when the only direct connection between audio common "ground" and true earth ground occurs in the preamplifier, through its grounded power cord. Other equipment in the system should have some form of isolation to prevent ground loops and associated hum.

Always place the power on-off switch on the front of the CLASSIC 60 in the OFF position before connecting the power line cord to AC power.

#### OPERATING PROCEDURE

1. Make sure you have read and complied with the INSTALLATION and CONNECTION instructions prior to attempting operation.
2. Make sure your CLASSIC 60 is properly connected to a high-current power receptacle via the attached power cord (see CONNECTIONS).
3. Your preamplifier should be "On" and muted and/or set at minimum gain.
4. Turn the POWER switch from "Off" to "Power." The green "Power" LED indicator should glow immediately. Approximately one (1) second later the green "High Voltage" fuse LED should also light up, indicating the proper operation of the high-voltage circuits. NOTE: If the "Power" or "High Voltage" indicator lamps fail to light, turn the "Power" switch to "Off" and check the appropriate fuses for possible failure. Extra fuses for both powerline and high-voltage circuits are packed with your CLASSIC 60.
5. Your CLASSIC 60 should now operate satisfactorily. However, a full stabilization or warm-up time of approximately one hour is recommended for best sonic performance.



## ADJUSTMENT PROCEDURE

NOTE: When removing top cover in preparation for any service adjustments, take care to unplug the fan cord from internal socket before lifting off cover completely. DO NOT ATTEMPT TO UNPLUG FANS UNLESS AMPLIFIER HAS FIRST BEEN DISCONNECTED FROM EXTERNAL AC POWER LINE.

The CLASSIC 60 utilizes very high quality, commercial and computer grade components which, together with conservative operation of all components and tubes, will provide long service life, if installed and operated within the parameters outlined in this Manual.

The output tubes, for example, are operated with electronically regulated "bias" voltage, that includes compensation for varying plate voltage as the line voltage changes. The resulting output tube current is essentially immune to line voltage variation within the normal range of 105-125VAC, or equivalent export line voltages.

After vacuum tube failure and replacement, it is desirable to make a single internal "bias" adjustment for optimum performance and tube life.

CAUTION: The following internal procedure should not be attempted by the owner unless he is technically qualified. There are high voltages within this unit which can be lethal under certain conditions. The internal "bias" adjustment should be accomplished by a qualified individual. It is necessary to remove the top and bottom covers from the CLASSIC 60 for this adjustment. The unit should be off before removal of the covers.

Normally, only the output tube idle current (bias voltage) requires adjustment in the CLASSIC 60. Use the plastic alignment tool provided for this adjustment.

The triode output stages of the CLASSIC 60 are partially cathode-coupled "push-pull Class AB<sub>1</sub>," utilizing our tightly coupled output transformers which provide low distortion and sonic accuracy.

As shipped from the factory, the output "bias" adjustments are set for a nominal 65mA per tube. Under these idle conditions the tubes are each dissipating approximately 32 watts of their 48 watt rating (42 watt plate, 6 watt screen). This point of operation provides "enriched" Class AB<sub>1</sub>, and will satisfy most critical listeners.

For best results, operate and adjust the CLASSIC 60 at 120VAC. Adjustment must be made under zero-signal conditions after at least 15-20 minutes of uninterrupted stabilization time.

A digital voltmeter capable of accurate measurements with 0.1mVDC resolution is preferred for accurate adjustment (must have 3 1/2 digit display). Use the plastic alignment tool provided to make the adjustment. The "bias" adjustment trimpot is accessible from the top of the circuit board, along the rear edge.

The four test points are accessible from the bottom of the circuit board, near the front edge. Test points TP1, TP2 on the schematic diagram are for tubes V9 and V11, and TP3, TP4 are for tubes V10 and V12. (Automatic servo balance circuits take care of tubes V5, V6, V7, V8).

WARNING. This adjustment involves measurements of circuits that are 420 volts DC above chassis potential, with large energy storage. Use extreme care to avoid shock hazard and to avoid damage to the CLASSIC 60 or to your meter due to careless use of test leads. All meter test leads connections must be isolated from chassis or earth ground. Start with the meter on its highest range before making connections, and then select the 200mV DC range. Do not attempt current measurements.

Adjust the "bias" for an average reading of 65 mVDC (.0650 Volt DC) between TP1-TP2 and between TP3-TP4. The two readings may differ by up to 10% because of minor variations in tubes.

### SERVO BALANCE CALIBRATION

The servo adjustments are factory set and should not require readjustment except in the event of a circuit malfunction or component replacement. They are not user adjustments and are not usually required when changing tubes.

Allow 20-30 minutes undisturbed warmup with top and bottom covers in place, to fully stabilize tube currents and servo circuit temperatures. The unit should be in a normal horizontal position, with its rubber feet resting on a hard surface for normal ventilation.

Tip the unit vertically on its handles, and remove the bottom cover. Connect a 3 1/2 digit DVM between TP2 and TP5. WARNING - high voltage.

Adjust the 15-turn trimmer through the guide on the left side of the chassis. Use the plastic alignment tool supplied with the unit (not a metal screwdriver). Adjust for a null of less than 0.2mVDC indication. Response is very slow and it may take 20-30 seconds for the reading to stabilize after adjustment. Some fluctuation is normal, so use the average reading. For best results, the line voltage should be stable at about 120VAC, although the actual line voltage is not critical.

Repeat for the right channel, using TP4 and TP6, and the right side trimmer.

### SERVICING

Because of its careful design and exacting standards of manufacture, your CLASSIC 60 amplifier should normally require only minimal service to maintain its high level of performance.

CAUTION: The CLASSIC 60 amplifier contains sufficient levels of voltage and current to be lethal. Do not tamper with a component or part inside the unit. Even with the power turned off, a charge remains in the energy storage capacitors for some time. Refer any needed service to your authorized Audio Research dealer or other qualified technician.

The twelve (12) vacuum tubes inside the CLASSIC 60 are high-quality 6550 and 6FQ7 tubes. Replacement tubes need not be matched, although slightly better sonic performance will result if matched sets are used. (Your CLASSIC 60 comes from the factory with a matched set installed.) Reliable, matched, low gas 6550 tubes -- such as those available from Audio Research -- are strongly recommended for maximum performance and longevity. Check bias adjustment after replacing tubes.

Additional questions regarding the operation, maintenance or servicing of your CLASSIC 60 amplifier may be referred to the Customer Service Department of Audio Research Corporation: 612/566-7570.

### CLEANING

To maintain the visual appearance of your CLASSIC 60 amplifier, occasionally wipe the front panel and top cover surfaces with a soft, damp (not wet) cloth to remove dust. A mild, non-alkaline soap solution may be used to remove fingerprints or similar smudges. Cleaners containing abrasives should not be used as they will damage the "brushed" grain of the front panel finish.

### 3-YEAR LIMITED WARRANTY TERMS AND CONDITIONS

1. LIMITED WARRANTY. Audio Research warrants the product designated herein to be free of manufacturing defects in material and workmanship, subject to the conditions hereinafter set forth, for a period of three (3) years from the date of purchase by the original purchaser or no later than five (5) years from the date of shipment to the authorized Audio Research dealer, whichever comes first, excepting vacuum tubes which are warranted for 90 days only (See 6).
2. CONDITIONS. This Warranty is subject to the following conditions and limitations. The Warranty is void and inapplicable if the product has been used or handled other than in accordance with the instructions in the owner's manual, abused or misused, damaged by accident or neglect or in being transported, or the defect is due to the product being repaired or tampered with by anyone other than Audio Research or an authorized Audio Research repair center. The product must be packed and returned to Audio Research or an authorized Audio Research repair center by the customer at his or her sole expense. Audio Research will pay return freight of its choice. A RETURNED PRODUCT MUST BE ACCOMPANIED BY A WRITTEN DESCRIPTION OF THE DEFECT AND A PHOTOCOPY OF THE ORIGINAL PURCHASE RECEIPT. This receipt must clearly list model and serial number, the date of purchase, the name and address of the purchaser and authorized dealer and the price paid by the purchaser. Audio Research reserves the right to modify the design of any product without obligation to purchasers of previously manufactured products and to change the prices or specifications of any product without notice or obligation to any person.
3. REMEDY. In the event the above product fails to meet the above Warranty and the above conditions have been met, the purchaser's sole remedy under this Limited Warranty shall be to return the product to Audio Research or an authorized Audio Research repair center where the defect will be rectified without charge for parts or labor, except vacuum tubes (See 6).
4. LIMITED TO ORIGINAL PURCHASER. This Warranty is for the sole benefit of the original purchaser of the covered product and shall not be transferred to a subsequent purchaser of the product.
5. DURATION OF WARRANTY. This Warranty expires on the third anniversary of the date of purchase or no later than the fifth anniversary of the date of shipment to the authorized Audio Research dealer, whichever comes first.
6. VACUUM TUBES. Vacuum tubes are warranted for the original 90-day period only.
7. DEMONSTRATION EQUIPMENT. Equipment used by an authorized dealer for demonstration purposes is warranted to be free of manufacturing defects in materials and workmanship for a period of three (3) years from the date of shipment to the dealer. Vacuum tubes are warranted for 90 days. Demo equipment needing warranty service must be packed and returned to Audio Research by the dealer at his sole expense. Audio Research will pay return freight of its choice. A returned product must be accompanied by a written description of the defect on an AUDIO RESEARCH RETURNED GOODS AUTHORIZATION form. Dealer-owned demonstration equipment sold at retail within three (3) years of date of shipment to the dealer is warranted to the first retail customer to be free of manufacturing defects in materials and workmanship for the duration of the 3-Year Limited Warranty remaining (as measured from the date of shipment of the equipment to the dealer). Vacuum tubes are not warranted for any period under these conditions of sale. In the event warranty service is needed under these conditions,

the owner of the equipment must provide a copy of his purchase receipt, fulfilling the requirements described under "2. Conditions" above. The product must be packed and returned to Audio Research or an authorized Audio Research repair center by the customer at his or her sole expense. Audio Research will pay return freight of its choice.

8. MISCELLANEOUS. ANY IMPLIED WARRANTIES RELATING TO THE ABOVE PRODUCT SHALL BE LIMITED TO THE DURATION OF THIS WARRANTY. THE WARRANTY DOES NOT EXTEND TO ANY INCIDENTAL OR CONSEQUENTIAL COSTS OR DAMAGES TO THE PURCHASER. Some states do not allow limitations on how long an implied warranty lasts or an exclusion or limitation of incidental or consequential damages, so the above limitations or exclusions may not apply to you. This Warranty gives you specific legal rights, and you may also have other rights which vary from state to state.

9. WARRANTOR. Inquiries regarding the above Limited Warranty may be sent to the following address:

**audio research**  
HIGH DEFINITION®  
5740 GREEN CIRCLE DRIVE  
MINNETONKA, MINNESOTA 55343-4424

WARRANTY OUTSIDE THE USA

Audio Research has formal distribution in many of the countries of the free world. In each country the Audio Research Importer has contractually accepted the responsibility for product warranty. Warranty should normally be obtained from the importing dealer or distributor from whom you obtain your product.

In the unlikely event of service need beyond the capability of the Importer, Audio Research does, of course, back up the warranty. Such product would need to be returned to Audio Research, together with a photostatic copy of the bill of sale.

CLASSIC 60 SPECIFICATIONS (AC line set @120V 60Hz for these specifications)

Power Output:

60 watts minimum continuous at 16 ohms from 15Hz to 20kHz with less than 1.0% total harmonic distortion (typically below .005% at 1 watt)

Approximate actual power available at "clipping": 62 watts (1kHz)

(Note that actual power output is dependent upon both line voltage and "condition" ie: if power line has high distortion, maximum power will be affected adversely, although from a listening standpoint this is not very critical.)

Power Bandwidth:

(-3dB Points) 12Hz to 40kHz

Input Sensitivity:

.55V RMS for rated output

Input Impedance:

100K ohms, nominal

Output Regulation:

Approximately 0.3dB 16 ohm load to open circuit  
(Damping factor approximately 30)

Negative Feedback:

20dB

Slew Rate:

20 volts/microsecond

Rise Time:

2.0 microseconds

Hum & Noise:

Less than 2.0mV RMS - 84dB below rated output (20kHz bandwidth unweighted, inputs shorted)

Power Supply Energy Storage:

Approximately 280 joules

Power Requirements:

105-125VAC 60Hz (210-250VAC 50Hz) 500 watts at rated output,  
700 watts maximum, 370 watts at "idle"

Dimensions:

19" (48 cm) W (standard rack panel) x 7" (18 cm) H x 15 3/4" (40 cm) D  
(front panel back). Handles extend 1 5/8" (4.1 cm) forward of the front panel. Output connectors extend 1" behind rear panel.

Weight:

63 lbs. (28.64 kg) Net; 76 lbs. (34.55 kg) Shipping

Tubes Required:

4 - Matched pair 6550 (low gas) - Power Output  
4 - 6FQ7/6CG7 - Drivers

# **audio research**

H I G H D E F I N I T I O N<sup>®</sup>

5740 GREEN CIRCLE DRIVE / MINNETONKA, MINNESOTA 55343-4424 / PHONE 612/939-0600 FAX 612/939-0604

MODEL CLASSIC 60  
STEREO POWER AMPLIFIER  
SCHEMATIC AND PARTS LIST

1-1-89

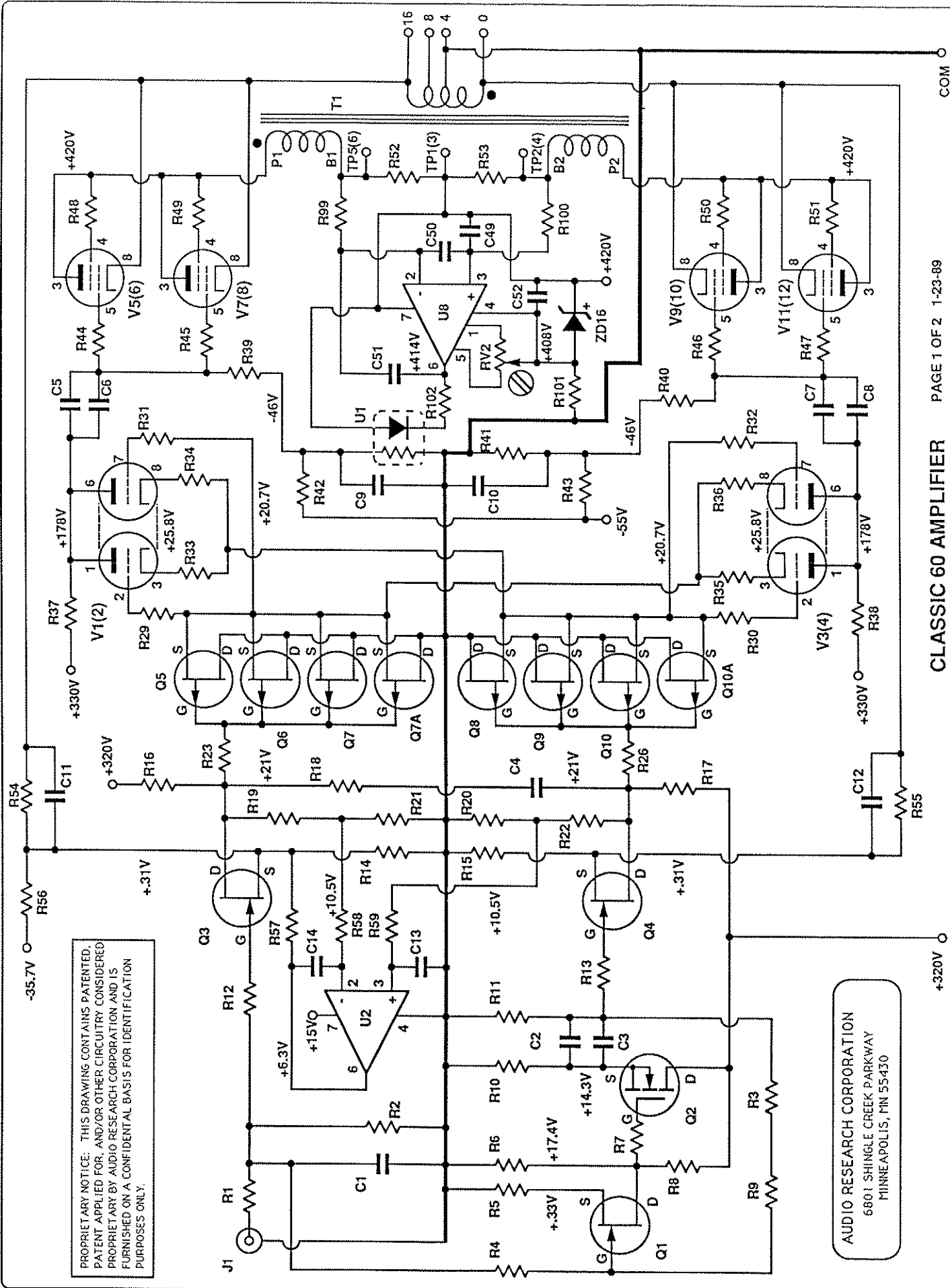

PROPRIETARY NOTICE: THIS DRAWING CONTAINS PATENTED, PATENT APPLIED FOR, AND/OR OTHER CIRCUITRY CONSIDERED PROPRIETARY BY AUDIO RESEARCH CORPORATION AND IS FURNISHED ON A CONFIDENTIAL BASIS FOR IDENTIFICATION PURPOSES ONLY.

AUDIO RESEARCH CORPORATION  
 6801 SHINGLE CREEK PARKWAY  
 MINNEAPOLIS, MN 55430



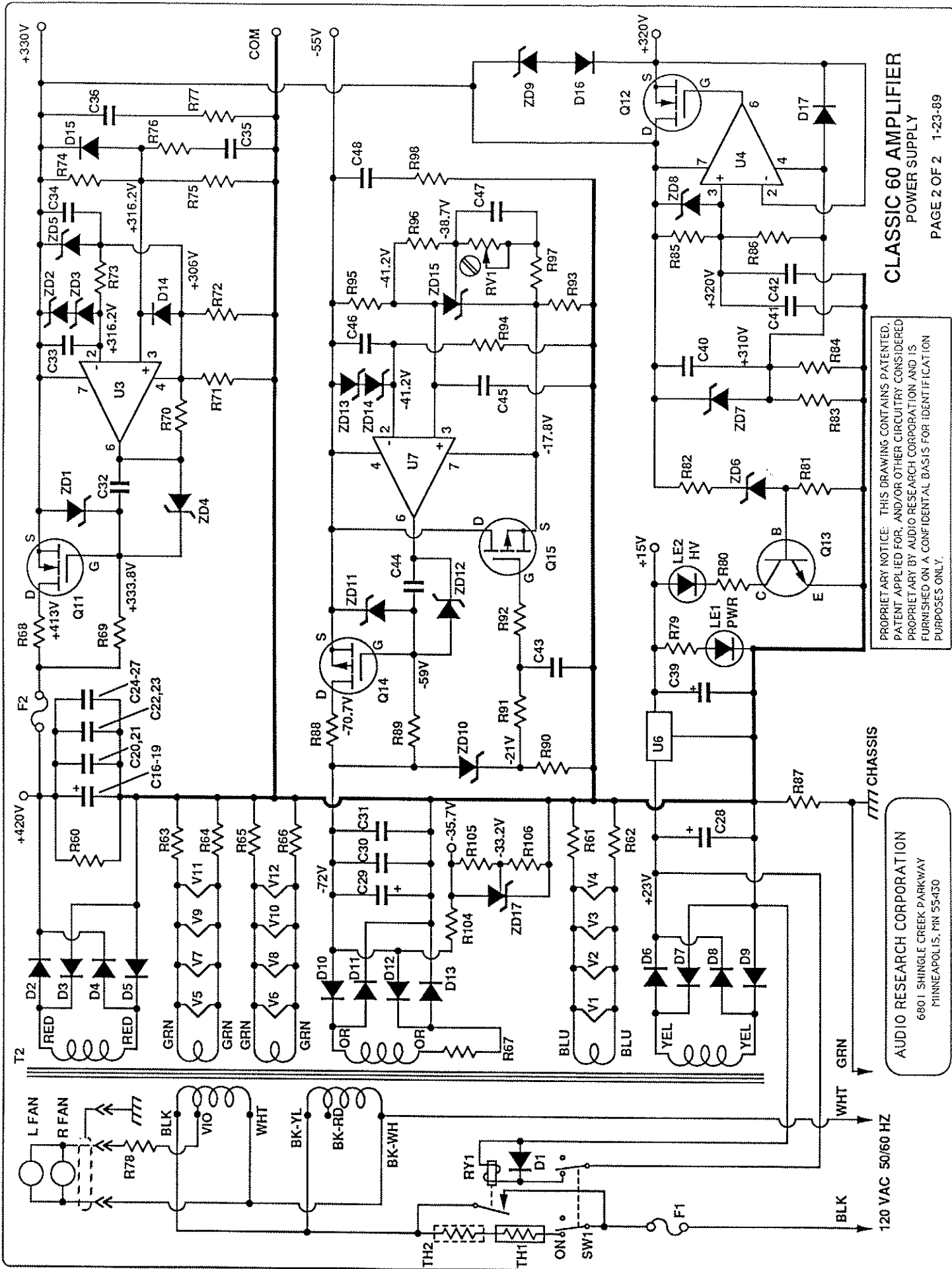

PROPRIETARY NOTICE: THIS DRAWING CONTAINS PATENTED, PATENT APPLIED FOR, AND/OR OTHER CIRCUITRY CONSIDERED PROPRIETARY BY AUDIO RESEARCH CORPORATION AND IS FURNISHED ON A CONFIDENTIAL BASIS FOR IDENTIFICATION PURPOSES ONLY.

AUDIO RESEARCH CORPORATION  
6801 SHINGLE CREEK PARKWAY  
MINNEAPOLIS, MN 55430

120 VAC 50/60 HZ  
WHT GRN  
/777 CHASSIS

## PARTS LIST

As of JAN 24 89

PRODUCT: CL60

CL60

NOTES:

| Schematic Symbol                   | Quantity | ARC Part# | Description                  |
|------------------------------------|----------|-----------|------------------------------|
| CAPACITORS                         |          |           |                              |
| C 1,1A,11,12                       | 8        | 53150202  | CAP. 150 PF 2 1/2% 630V PPN  |
| C 2,5,8,24,25,26,27,31,35,41       | 13       | 53100406  | CAP. .01 MFD +/- 10% 630 V   |
| C 3                                | 2        | 53100606  | CAP. 1 MFD +/- 10% 250V      |
| C 4                                | 2        | 53330200  | CAP. 330 PF 2 1/2% 160V      |
| C 6,7                              | 4        | 53100800  | CAP. 1 MFD 450V              |
| C 9,10,47,52                       | 7        | 53100408  | CAP. .01 MF 10% 63V PPN      |
| C 13,14,32,33,34,40,43,44,46,49,51 | 15       | 53220507  | CAP. .22 MF 10% 160V         |
| C 16,17,18,19                      | 4        | 50800801  | CAP. 800MF 450V GRAY         |
| C 20,21,36,42                      | 4        | 53200602  | CAP. 2 MFD+/-10% 450V        |
| C 28                               | 1        | 50680800  | CAP. 680 MFD 35V             |
| C 29                               | 1        | 50470802  | CAP. 470 MF 100V LYTIC       |
| C 30                               | 1        | 53470511  | CAP. .47MF +/-20% 250V       |
| C 39                               | 1        | 51220601  | CAP. 2.2 MF+/-10% 25V        |
| C 45                               | 2        | 53100505  | CAP. .1 MF 10% 63V MPCN      |
| C 48                               | 1        | 53200603  | CAP. 2 MFD +/- 10% 250V      |
| C 50                               | 2        | 53220306  | CAP. 2200 PF 10% 100VDC      |
| DIODES                             |          |           |                              |
| D 1,6,7,8,9,10,11,12,13            | 9        | 30500400  | IN4005 GENERAL INSTRUMENT    |
| D 2,3,4,5                          | 4        | 30503310  | EDAL #M4G5                   |
| D 14,15,16,17                      | 4        | 30500910  | FAIRCHILD IN916B             |
| FUSES                              |          |           |                              |
| F 1 (100V)                         | 1        | 34500703  | FUSE, MDX7                   |
| F 1 (220/240V)                     | 1        | 34500704  | FUSE, MDA-4                  |
| F 1 (120V)                         | 1        | 34501000  | FUSE, 6-1/4 MDX              |
| F 2                                | 3        | 34500102  | FUSE, BUSSMAN AGC 1/4 250V   |
| CONNECTORS                         |          |           |                              |
| J 1 (R)                            | 1        | 23201501  | GOLD PHONO JK.,W/RD.BND.SP11 |
| J 1 (L)                            | 1        | 23201502  | GOLD PHONO JK.,W/WH.BD.SP11  |
| PANEL INDICATOR                    |          |           |                              |
| LE 1,2                             | 2        | 34300102  | LED,COLLAR & RETAINING RING  |
| TRANSISTORS                        |          |           |                              |
| Q 1                                | 2        | 30006503  | FET, WHITE ORANGE            |
| Q 2                                | 2        | 30006724  | FET, ORANGE RED YELLOW       |
| Q 3,4                              | 4        | 30006527  | FET, WHITE RED VIOLET        |
| Q 5,6,7,7A,8,9,10,10A              | 16       | 30006461  | FET, BLUE, ORG, BRN          |
| Q 11                               | 1        | 30006836  | FET, GREEN BLUE              |
| Q 12                               | 1        | 30007102  | FET, YELLOW RED              |
| Q 13                               | 1        | 30002800  | TRANSISTOR,2N4401            |
| Q 14                               | 1        | 30006200  | MTP 2P45                     |
| Q 15                               | 1        | 30007029  | FET, GRAY WHITE              |
| RESISTORS                          |          |           |                              |
| R 78 (FAN GRADE C)                 | 1        | 43500100  | RES. 50 OHM +/-5% 4 1/2W     |
| R 78 (FAN GRADE E)                 | 1        | 43100202  | RES. 100 OHM 2W 5%           |
| R 78 (FAN GRADE L)                 | 1        | 43150201  | RES. 150 OHM 2W 5%           |
| R 78 (FAN GRADE R)                 | 1        | 43270200  | RES. 270 OHM 2-3W +/-1%      |
| R 1                                | 2        | 42100314  | RES. 1K 1% MK-5 50PPM        |
| R 2                                | 2        | 42432503  | RES. 432K 1% MK-3 50PPM      |
| R 3,73                             | 3        | 42499303  | RES. 4.99K 1% MK-3 50PPM     |
| R 4,9                              | 4        | 42127503  | RES. 127K 1% MK-3 50PPM      |
| R 5,12,13,14,15                    | 10       | 42150203  | RES. 150 OHM 1% MK-3 50PPM   |
| R 6,57                             | 4        | 42215403  | RES. 21.5K 1% MK-3 50PPM     |
| R 7,67,87                          | 4        | 42100103  | RES. 10 OHM 1% MK-3 50PPM    |
| R 8,37,37A,37B,                    | 22       | 42100505  | RES. 100 1% MK-8 50PPM       |
| R 10,33A,34A,35A,36A,42,42A,43,43A | 18       | 42392303  | RES. 3.92K 1% MK-3 50PPM     |

## PARTS LIST

As of JAN 24 89

PRODUCT: CL60

CL60

NOTES:

| Schematic Symbol     | Quantity | ARC Part# | Description                  |
|----------------------|----------|-----------|------------------------------|
| R 11,97A             | 3        | 42100603  | RES. 1 MEG 1% MK-3 50PPM     |
| R 16,17              | 4        | 42825405  | RES. 82.5K 1% MK-8 50PPM     |
| R 18,41,41A,74,90,94 | 9        | 42150403  | RES. 15K 1% MK-3 50PPM       |
| R 19,20,21,22,95     | 9        | 42750303  | RES. 7.5K 1% MK-3 50PPM      |
| R 23,26,88           | 5        | 42549103  | RES. 54.9 OHM 1% MK-3 50PPM  |
| R 29,30,31,32        | 8        | 42499203  | RES. 499 OHM 1% MK-3 50PPM   |
| R 33,34,35,36        | 8        | 42301303  | RES. 3.01K 1% MK-3 50PPM     |
| R 44,45,46,47,79,80  | 10       | 42100303  | RES. 1K 1% MK-3 50PPM        |
| R 48,49,50,51        | 8        | 43100200  | RES. 100 OHM 5% 2W           |
| R 52,53              | 4        | 43050004  | RES. 0.5 OHM+/-2% 3W W.W.    |
| R 54,55              | 4        | 42511313  | RES. 5.11K 1% MK-4 50PPM     |
| R 56,82              | 3        | 42121503  | RES. 121K 1% MK-350PPM       |
| R 58,59,99,100       | 8        | 42464603  | RES. 4.64 MEG. 1% MK-3 50PPM |
| R 60,101             | 3        | 42300514  | RES. 300K 1% MK-5 50PPM      |
| R 61,62,63,64,65,66  | 6        | 42100203  | RES. 100 OHM 1% MK-3 50PPM   |
| R 68                 | 1        | 46100201  | RES. POWER OX.100 OHM 5% 3W  |
| R 69,91              | 2        | 42301503  | RES. 301K 1% MK-3 50PPM      |
| R 70                 | 1        | 42392403  | RES. 39.2K 1% MK-3 50PPM     |
| R 74A,104            | 2        | 42178403  | RES. 17.8K 1% MK-3 50PPM     |
| R 75                 | 1        | 42280513  | RES. 280K1% MK-4 50PPM       |
| R 75                 | 1        | 42562513  | RES. 562K 1% MK-4 50PPM      |
| R 76                 | 1        | 42332203  | RES. 332 OHM 1% MK-3 50PPM   |
| R 77,98              | 2        | 43100002  | RES. 1 OHM 2W 5% W.W.        |
| R 81,105             | 2        | 42100403  | RES. 10K+/-1% MK-3 50PPM     |
| R 85,86              | 2        | 42100703  | RES. 10 MEG 1% MK-3 50PPM    |
| R 92                 | 1        | 42432103  | RES. 43.2 OHM 1% MK-3 50PPM  |
| R 93                 | 1        | 42121303  | RES. 1.21K 1% MK-3 50PPM     |
| R 96                 | 1        | 42274403  | RES. 27.4K 1% MK-3 50PPM     |
| R 97                 | 1        | 42162503  | RES. 162K 1% MK-3 50PPM      |
| R 102                | 2        | 42357403  | RES. 35.7K 1% MK-3 50PPM     |
| R 106                | 1        | 42133503  | RES. 133K 1% MK-3 50PPM      |
| CONTROLS             |          |           |                              |
| RV 1                 | 1        | 45100527  | POT. 100 K 10%               |
| RV 2                 | 2        | 45500301  | TRIM POT, 5K 10% 15 TURN     |
| RELAYS               |          |           |                              |
| RY 1                 | 1        | 64101200  | RELAY, 24V T90 POWER ON      |
| TRANSFORMERS         |          |           |                              |
| T 1                  | 2        | 60008100  | XFR. CL60 OUTPUT,REV.A       |
| T 2                  | 1        | 60006001  | XFR. D115 ALL VOLT. REV.E    |
| THERMISTORS          |          |           |                              |
| TH 1,2               | 2        | 47000300  | THERMISTOR 30 OHM +/-20%     |
| INTEGRATED CIRCUITS  |          |           |                              |
| U 1                  | 2        | 34400120  | PHOTO COUPLER                |
| U 2,4                | 3        | 31001900  | TLO71CP                      |
| U 3,7                | 2        | 31002200  | MC 34071 P MOTOROLA          |
| U 6                  | 1        | 31002000  | D70/D115/D250 MC7815CT       |
| U 8                  | 2        | 31002401  | LF 441 CN TESTED-ACCEPT      |
| VACUUM TUBES         |          |           |                              |
| V 1,2,3,4            | 4        | 32000201  | VAC.TUBE, 6CG7/6FQ7          |
| V 5,6,7,8,9,10,11,12 | 8        | 32000501  | VAC.TUBE, 6550 [TESTED ]     |
| ZENER DIODES         |          |           |                              |
| ZD 1,11              | 2        | 30500300  | IN 4740A                     |
| ZD 2,3,13,14         | 4        | 31000705  | LM329DZ                      |
| ZD 4                 | 1        | 30504200  | IN5535A                      |
| ZD 5                 | 1        | 30503500  | IN5359 B                     |

## PARTS LIST

As of JAN 24 89

PRODUCT: CL60

CL60

NOTES:

| Schematic Symbol | Quantity | ARC Part# | Description                   |
|------------------|----------|-----------|-------------------------------|
| ZD 6             | 1        | 30503600  | TZB 250A TRANSIENT SUPPRESSOR |
| ZD 7,8,9         | 3        | 30503700  | DIODE, Z20 10%                |
| ZD 10            | 1        | 30504700  | DIODE, 1N5262B                |
| ZD 12            | 1        | 30501800  | IN5245B                       |
| ZD 15,17         | 2        | 31002600  | ZENER DIODE, TL431CLP ADJ     |
| ZD 16            | 2        | 30502700  | IN4742-A                      |